

FORZA 

**Mordaza de Taladro
Serie 82**

**Press drill Vice
82 Series**



Serie 82

ÍNDICE

- 
- | | |
|---|---|
| 1. Características técnicas
Technical Features | 4 |
| 2. Dimensiones de la mordaza
Machine vice dimensions | 4 |
| 3. Bases giratorias
Swivel bases | 5 |
| 4. Bocas para las mordazas
Jaws vices | 6 |
| 5. Tuercas en T para ls mordazas
T-nuts for vices | 6 |
| 5. Varilla de apriete para mordazas
Tightening rod for vices | 7 |
| 6. Despiece de la mordaza
Spare parts | 7 |

■ 1. CARACTERÍSTICAS TÉCNICAS / TECHNICAL FEATURES

Construida en fundición nodular.

Admite base giratoria (opcional).

Con bocas duras con escalón.

Tiene todas la piezas iguales a la serie 33. Excepto el portabocas móvil y la boca móvil, que en el caso de la serie 82 es una pieza monobloque.

El portabocas móvil tiene escalon y prisma a 90° para amarrar redondos

Built in nodular cast.

Admit optional swivel base (optional).

With hard jaws with step.

It has all the parts equal to the series 33. Except the movil jaw holder and the movable jaw, which in the case of the series 82 is a monobloc piece.

The movable jaw holder has a step and prism to 90°.



■ 2. DIMENSIONES DE LA MORDAZA / MACHINE VICE DIMENSIONS

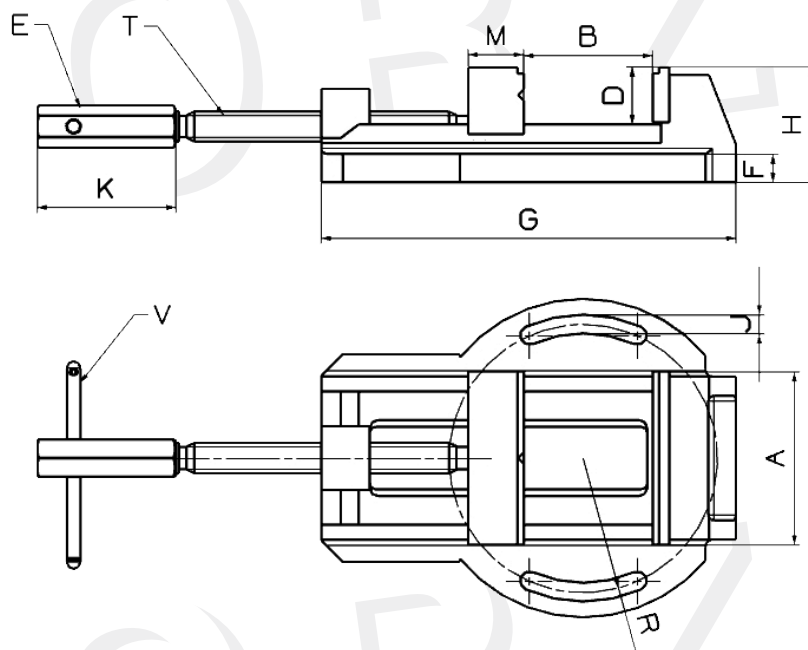

Ref.	A	B	D	E	F	G	H	J	K	M	R	T	V	Peso
82/85	85	95	25,5	22	14,5	188	54	9	81	25	62	18x4	336509	4,3
82/100	105	116	31,5	24	18	241	66	11	90	40	82	20x4	111883	8,5
82/125	125	160	41,5	27	20,5	300	83	11	102	40	97	22x5	111883	17,5
82/150	150	190	52,5	27	21	345	95	16	102	40	105	22x5	111883	23

■ **3. BASES GIRATORIAS / SWIVEL BASES**

Los agujeros N son para amarrar la mordaza a la base giratoria, los agujeros M son para amarrar la base a la mesa del taladro. También se pueden amarrar las bases giratorias a los taladros con bridas.

The holes N are for clamped the vice to the swivel base, the holes M are for clamped the base to the drill table. The swivel bases can also be clamped to the drill table with clamps.

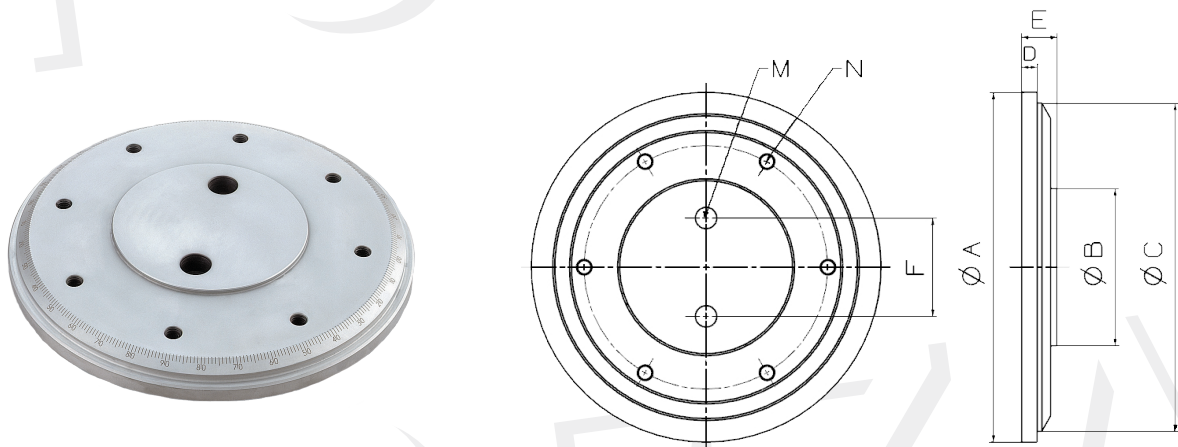

Ref.	ØA	ØB	ØC	D	E	M	N	F	Peso	Brida
336598	160	60	149	8	17	M-10	M-8	40	2,1	336560
339598	178	80	167	8	18	M-10	M-8	50	2,7	336560
3310098	229	115	201	10	22	M-12	M-10	80	5,6	12560
3312598	259	125	247	10	22	M-12	M-10	80	7,6	12560
3315098	294	150	280	10	23	M-12	M-10	90	9,2	12560

Brida para base giratoria
Swivel base clamp

Ref. Brida	Para base giratoria / For swivel base	Mordaza / Vice
336598	336598 - 338598	33/65 - 33/85
339598	3310098 - 3312598	33/100 - 33/125 - 85/150



4. BOCAS PARA LAS MORDAZAS / JAWS VICES

Solo se pueden cambiar las bocas fijas. Se utilizan las mismas que para la serie 33 / Only the fixed mouths can be changed. The same are used as for series 33.

Boca Standard
Standard jaw

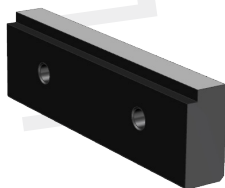

Boca Prismatica
Prismatic jaw



Boca Blanda
Soft jaw

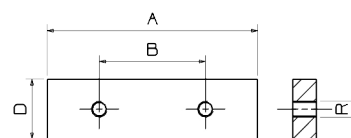
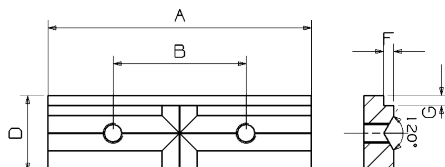
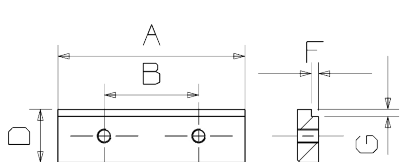
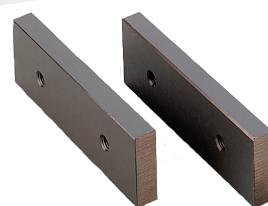

Ref.	B. Blanda Soft jaw	B.Standard S. Standard	B.Prismat	A	B	D	F	G	R
33/65	336550	336514	336551	65	26	25	3	3	M-6
33/85	338550	338514	338551	85	45	25	3	3	M-6
33/100	3310050	3310014	3310051	105	53	30	4	4	M-8
33/125	3312550	3312514	3312551	125	65	40	4,5	4,5	M-8
33/150	3315050	3315014	3315051	150	75	48	6	6	M-10

5. TUERCAS EN T PARA MORDAZAS / T-NUTS FOR VICES

Se utilizan para introducir en la ranura de la mesa del taladro y así se puede roscar los tornillos de sujeción de la mordaza y la base giratoria.

They are used to insert into the groove of the drill table and thus can be threaded the clamping screws of the jaw and the swivel base.

Ref.	Mordazas	Referencia	Rosca	Par T de:
33121408	33/65 y 33/85	33121408	M-8	12 y 14 mm
33161808	33/65 y 33/85	33161808	M-8	16 y 18 mm
33121410	33/100 y 33/125	33121410	M-10	12 y 14 mm
33161810	33/100 y 33/125	33161810	M-10	16 y 18 mm
33161814	33/150	33161814	M-14	16 y 18 mm
33202214	33/150	33202214	M-14	20 y 22 mm



■ **6. VARILLA DE APRIETE PARA LAS MORDAZAS / TIGHTENING ROD FOR VICES**



Mordaza	Varilla	Ø	L
33/65	336509	8	120
33/85	336509		
33/100	111893	10	150
33/125	111893		
33/150	111893		

■ **7. DESPIECE DE LA MORDAZA / VICE EXPLORED VIEW**

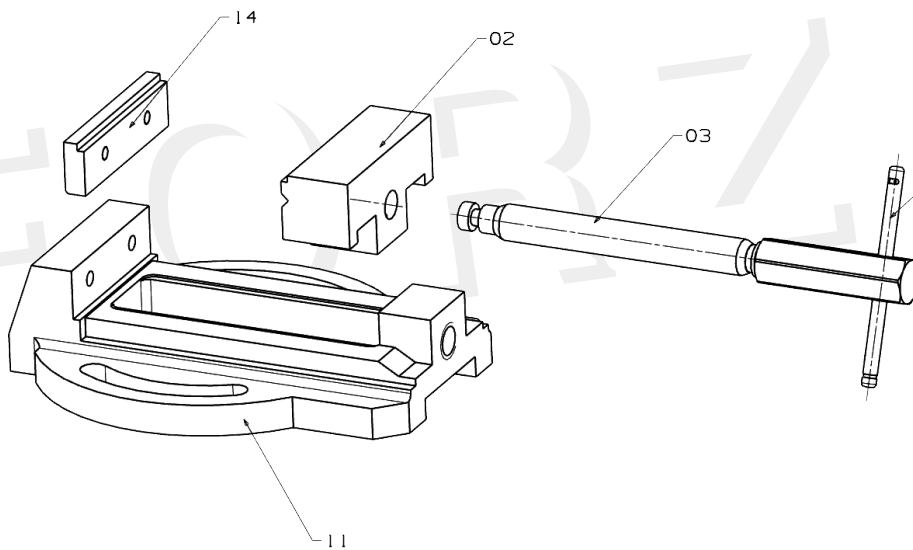



S.L. de Herramientas Especiales Forza
C/ San Miguel de Atxa, 24
01010 Vitoria
www.forza.es

